

NEW FROM PARADIGM



PARADIGM REFERENCE

A Music and HT System designed to deliver multiple OH's!

OH!

Available as a 5.0 or 2.0 system ... for music, movies and best sound and impact on the market for gaming! The 2.0 system also ideal as rear speakers in a knock 'em dead 7.1 system! Includes tabletop stands.

OH!

1" S-PAL™ satin-anodized pure-aluminum domes
4" S-PAL™ satin-anodized pure-aluminum cones
Powerful rare-earth neo magnets



OH! WOW

Compact die-cast aluminum speaker enclosures. Superior rigidity in a thin, sexy design that allows for larger, more powerful drivers. Low-resonance cabinets with a gorgeous contemporary gloss finish (Black or White).

OMG!

MilleniaSub! The most flexible Paradigm sub ever! More placement positions than a swami teaching yoga in an ashram! Dual opposite-firing 14" x 3" woofers. 900 Watts Dynamic Peak power! Black or White Satin finish.

MilleniaOne™
2.0 OR 5.0 SYSTEMS

MilleniaSub™



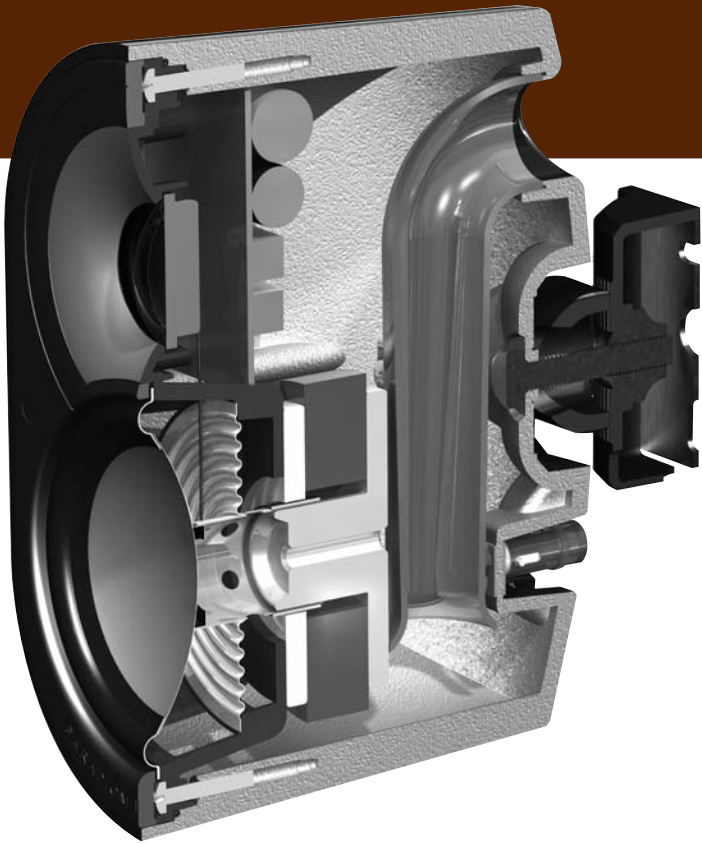

Molded 1" Aluminum Domes ... anodized silver color finish. Powerful rare-earth neodymium magnets deliver incredible energy in the gap!

Single-Piece 4" Aluminum Bass/Mid Cones ... anodized silver color finish. Single-piece construction allowed us to improve the cone modal vibration pattern and bingo — better frequency response immediately.

Optimized Magnet/Motor Structure ... more attention to detail in the optimizing of the structure than anything found in a big box store ... and anything else claiming to be high-end quality for that matter!

Die-cast Aluminum Cabinets ... a thicker wooden cabinet (same external dimensions) wouldn't have allowed us to fit the large, powerful drivers. And since aluminum is a superb conductor of heat, the enclosure also functions as a heatsink.

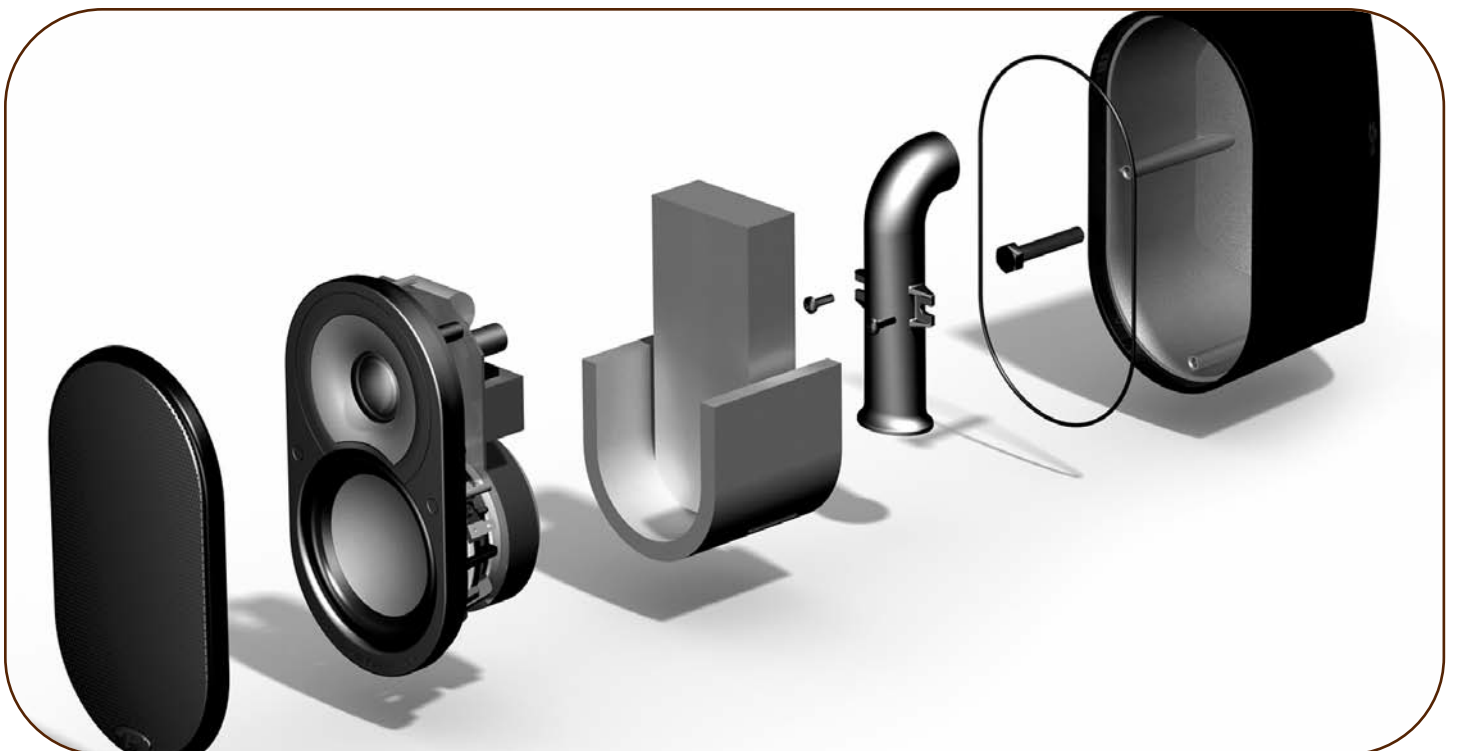

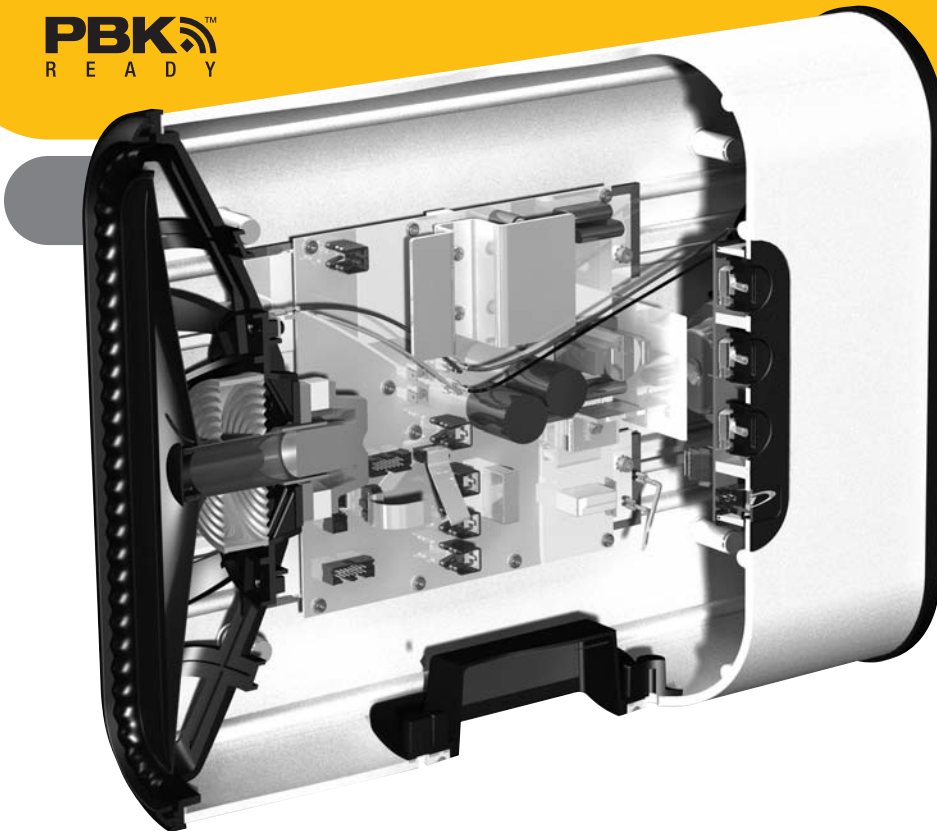

900 Watts Dynamic Peak Power
300 Watts RMS Sustained

14" x 3" cone ... just shy of a full inch of peak-to-peak cone travel!

Back-to-Back Bipolar Dual-Woofer Design ... inherently vibration-canceling. Woofers fire in opposite directions resulting in a physical cancellation of cabinet vibrations and a massive reduction in the potential for sound-destroying resonances. Bloated, boomy bass? Not a chance!

Killer Polymer Monocoque Cone Design ... the outer skin of the cone bears the brunt of the motion stress brought on by extended cone movement! Cone is also FEA-optimized for the maximum strength-to-weight ratio.

Over-Molded Corrugated Santoprene® Surround ... well known performance advantages like high-excursion and symmetrical compliance as well as increased longevity and you-can-bank-on-it performance reliability. Design geometry reminiscent of our RVC-12SQ in-wall sub = higher output, lower distortion, every bass note sounds distinct.

Radical Dustcap Design ... braced through the center and adhered to the cone's edge allowed us to move primary cone breakup mode to outside the woofer's operating band. Reduced distortion (it's inaudible actually!) and improved frequency response. Not to mention it looks totally cool!

FEA-Optimized Motor Structure ... 1" voice-coil, high-energy rare-earth neodymium ring magnets.

5-mm Thick Die-Cast Aluminum Cabinet ... ultra-rigid but also super slim allowing us space to tuck in all of this crazy state-of-the-art technology!

Advanced Ultra-Class-D™ Amplifier ... Paradigm's Digital Signal Processing Design. Sophisticated mathematical algorithms 'shape' frequency response ensuring accurate, consistent, musical bass without distortion even at highest output levels.

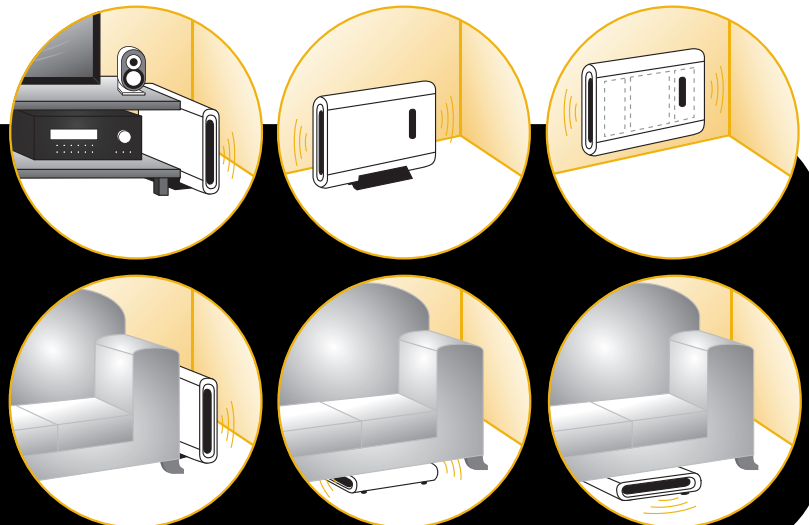

Talk About Sub Yoga - check out this positioning matrix. No Paradigm sub has ever offered so many placement options!

Design (each speaker including center channel)	2-driver, 2-way vented die-cast aluminum enclosures with integrated baffle and chassis. Low-diffraction grilles maximize imaging and ensure smooth dispersion.
Crossover	3rd-order electro-acoustic at 2.2 kHz
High-Frequency Driver	25-mm (1 in) S-PAL™ satin-anodized pure-aluminum dome
Bass / Midrange Driver	155-mm (4 in) S-PAL™ satin-anodized pure-aluminum cone
Low-Frequency Extension*	76 Hz (DIN)
Frequency Response: <i>On-Axis</i> <i>30° Off-Axis</i>	±2 dB 120 Hz – 20 kHz ±2 dB 120 Hz – 18 kHz
Sensitivity – Room / Anechoic	89 dB / 86 dB
Suitable Amplifier Power Range	15 – 100 watts
Maximum Input Power	50 watts
Impedance	Compatible with 8 ohms
Height, Width, Depth (not including stand)	19.5 cm x 11.5 cm x 14.5 cm (7¾ in x 4½ in x 5¾ in)
Weight (unpacked, not including stand / hardware)	2.45 kg / 5.4 lb each
Weight (unpacked, including stand / hardware)	2.96 kg / 6.5 lb each
Finishes	Gloss Black, Gloss White
Accessories (included)	Tabletop / Shelf Stands and Wall-Mounting Brackets

MilleniaSub

Design	Dual driver, sealed box, vibration cancelling, built-in Ultra-Class D™ power amplifier, built-in wireless receiver for wireless option, USB port for PBK equalization
Amplifier: High-Current, Discrete Output	900 Watts Dynamic Peak / 300 Watts RMS Sustained
Amplifier Design Features	Auto-on, soft clipping, thermal monitoring
Bass Drivers	Two 355-mm x 76-mm (14 in x 3 in) reinforced polymer cones, corrugated Santoprene® surrounds, 25-mm (1 in) voice-coils
Low-Frequency Extension*	21 Hz (DIN)
Subwoofer Cut-Off Frequency	Variable 35 Hz – 150 Hz; Bypass option
Sub / Sat Phase Alignment	Variable 0° – 180°
Line-Level Inputs	RCA Sub-Out / LFE-Out of receiver / processor or other line-level source
Height, Width, Depth (horizontal, including feet)	13.75 cm x 46.5 cm x 35.5 cm (5½ in x 18¾ in x 14 in)
Height, Width, Depth (vertical, including stand)	38.25 cm x 12.5 cm (stand width 17.9 cm) x 46.5 cm (15 in x 4¾ in (stand width 7 in) x 18¾ in)
Height, Width, Depth (on-wall, including hardware)	35.6 cm x 46.5 cm x 15.0 cm (14 in x 18¾ in x 5¾ in)
Weight (unpacked, not including stand / hardware)	10.9 kg / 24 lb each
Weight (unpacked, including stand / hardware)	11.2 kg / 24.5 lb each
Finishes	Satin Black, Satin White
Accessories (sold separately)	MilleniaSub Wall-Mount Bracket system Paradigm Perfect Bass Kit room correction system Paradigm PT-2 Wireless Transmitter (see below left)



Wireless Option Only

(Using Paradigm PT-2 Transmitter sold separately, see dealer)

RF Frequency	2.4 GHz
Latency	Selectable (15 / 20 / 25 ms)
Transmission Range	50 ft / 15 m
Sampling Frequency / # Bits	48 KHz / 16 bits
Connectivity	Up to four subwoofers per PT-2 transmitter

*DIN 45 500. Indicates -3 dB in a typical listening room.

Paradigms,
they put you in the moment
and keep you there!

Paradigm® and all of its associated patented and proprietary designs and technologies are registered trademarks of Paradigm Electronics Inc. Copyright © Paradigm Electronics Inc. All rights reserved. All other trademarks are the property of their respective owner(s). We reserve the right to change specifications and/or features without notice as design improvements are incorporated. www.paradigm.com.